

ARCHITECTURE



Quentin LUCAS

ARCHITECTURE STUDENT

quentin.lucas@paris-valdeseine.archi.fr



SKILLS

LAYOUT

Autocad _____
 Photoshop _____
 InDesign _____
 Illustrator _____
 Office _____

LANGUAGES

French _____
 English _____
 Spanish _____

MODELING

Révit _____
 Twinmotion _____
 Cinéma 4D _____

VIDEO EDITING

Première _____
 After effect _____

ACHIEVEMENTS

- | | | | | |
|------|--|---|------|---|
| 2020 | Bachelor 's thesis :
Saint-Pierre-et-Miquelon
Drifts of an climatic architecture | : | 2016 | Amator feature :
Le Neuvième - L'avènement |
| | | | 2014 | |
| | | | 2015 | Photographic prize for Oceans
Day |
| 2017 | FIER SPM Ambassador | | | |
| 2017 | Associative project
« Mots'Dites Îles » | | | |

EXPERIENCE

2019 - 2023

La passerelle immobilier
 - Vertical extention of a commercial agency
 - Reorganisation of an old residence

Silvio d'Ascia architecture INTERNSHIP
 - SCHEMATIC DESIGN: ZAC Tremblay
 - SCHEMATIC DESIGN Fondation Maeght
 - DESIGN DEVELOPMENT : Centre commercial

Cabinet of Minister of Overseas INTERNSHIP
 Housing mission

2016 - 2019

Pierre Antoine Gatier STAGE
 Chief Architect of historical monuments
 - Chantilly Castle
 - Palais des papes, Avignon
 - Saint-Louis's church

2018 - 2019

La passerelle immobilier
 Realisation of an touristic residence

Rénovation of a farm INTERNSHIP
 Heritage workshop «Rempart»

Greeter
 Mahola Hôtesses - Selectively

Tourist and Nature Guide
 Nature's house of Saint-Pierre-et-Miquelon

2013 - 2016

R. Victorri STAGE
 Building control and modeling

EDUCATION

Architecture Master
 ENSA of Paris-Val de Seine

2020

2020
 5 MONTHS

2019
 3 MONTHS

Bachelor of architecture
 ENSA of Paris-Val de Seine

2019
 1 MONTH

Bachelor of architecture
 Umeå School of Architecture, Suède
 Erasmus exchange

2018

2018

2017 - 2020

2016 & 2017

Baccalauréat scientifique
 Mention GOOD - Option Arts
 Lycée Emile Letournel,
 Saint-Pierre-et-Miquelon

2013

THEORETICAL PROJECTS

- 2020 **Productive city**
School, industry, housing, urbanism
- 2020 **Stand-out edifice**
Tower with a mixte program
- 2019 **Trans-rural lab**
Housing, hall, urbanism
- 2018 **Sytopia**
Housing, comercial space
- 2018 **High density housing**
Collectif dwelling
- 2017 **Thermal bath in Paris**
Thermal bath
- 2017 **Slope living**
Individual house
- 2017 **Swimming**
Swimingpool for the Tuscon House
- 2017 **From the big to the small**
Dance hall at the National Library
- 2017 **An entrance for « le jardin des plantes »**
Entrance for a majestic space
- 2016 **Reading**
Publique library

COMPETITIONS

- 2020 **Competition of Jacque Rougerie's fondation**
Sea urbanism
- 2020 **COAL Prize**
Bioclimatic architecture

PROJECTS UNDER-CONSTRUCTION

- 2020 **Villa Paturel**
Reorganisation of an old residence
- 2020 **Allianz**
Vertical extension of a commercial agency
- 2018 **Residences**
Tourist residence

SELECTED PROJECTS

- 2020 **Productive city** 7.
School, industry, housing, urbanism
- 2019 **Trans-rural lab** 19.
Housing, hall, urbanism
- 2018 **Sytopia** 27.
Housing, comercial space
- 2017 **Sloap living** 33.
Individual house
- 2018 **Residences** 39.
Tourist residence

INTERESTS

45.

LETTERS OF RECOMMANDATION

51.

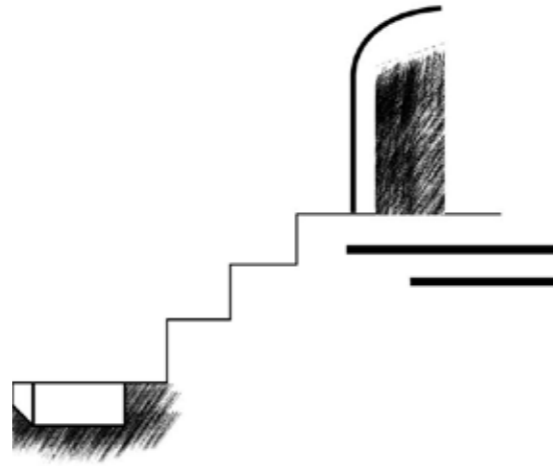

PRODUCTIVE 1. CITY

REBUILDING THE INDUSTRIAL CITY

DUO ENSA Paris-Val de Seine - Master 1 - 2020

Building the city on the city is a way to limit the expansion of urban areas. This is the main goal of most cities.

This gives us the opportunity to build differently, have a vision of the territory as a resource for the project and to imagine a more balanced use of the space.

The goal is to oppose the idea of zoning and territorial mono-functionalism and rethink a productive system of the city around suitability principles, creation, formation, circular economies and solidarity and diversity of uses.

« Les crottes », a neighborhood in the North of Marseille, is a territory left to the control of its inhabitants, most of them blue collar workers. Infrastructures: roads, highway, above ground metro and train lines shows the domination of the agglomeration. A logistic platform, damaging but invisible, it's intensifying the feeling of being surrounded by walls.

The project "Gallery" is a school, inspired by Bauhaus which is trying to be an example of celebrating and refreshing its own heritage. It makes sense in the current context of saving materials. Pressing the destruction button shouldn't be automatic. Reusing materials is now fundamental of construction.

Demolishing a building should no longer be the sign of erasure, but the affirmation of the characteristics of the site which need to evolve with the city and even more: the metropolitan area.

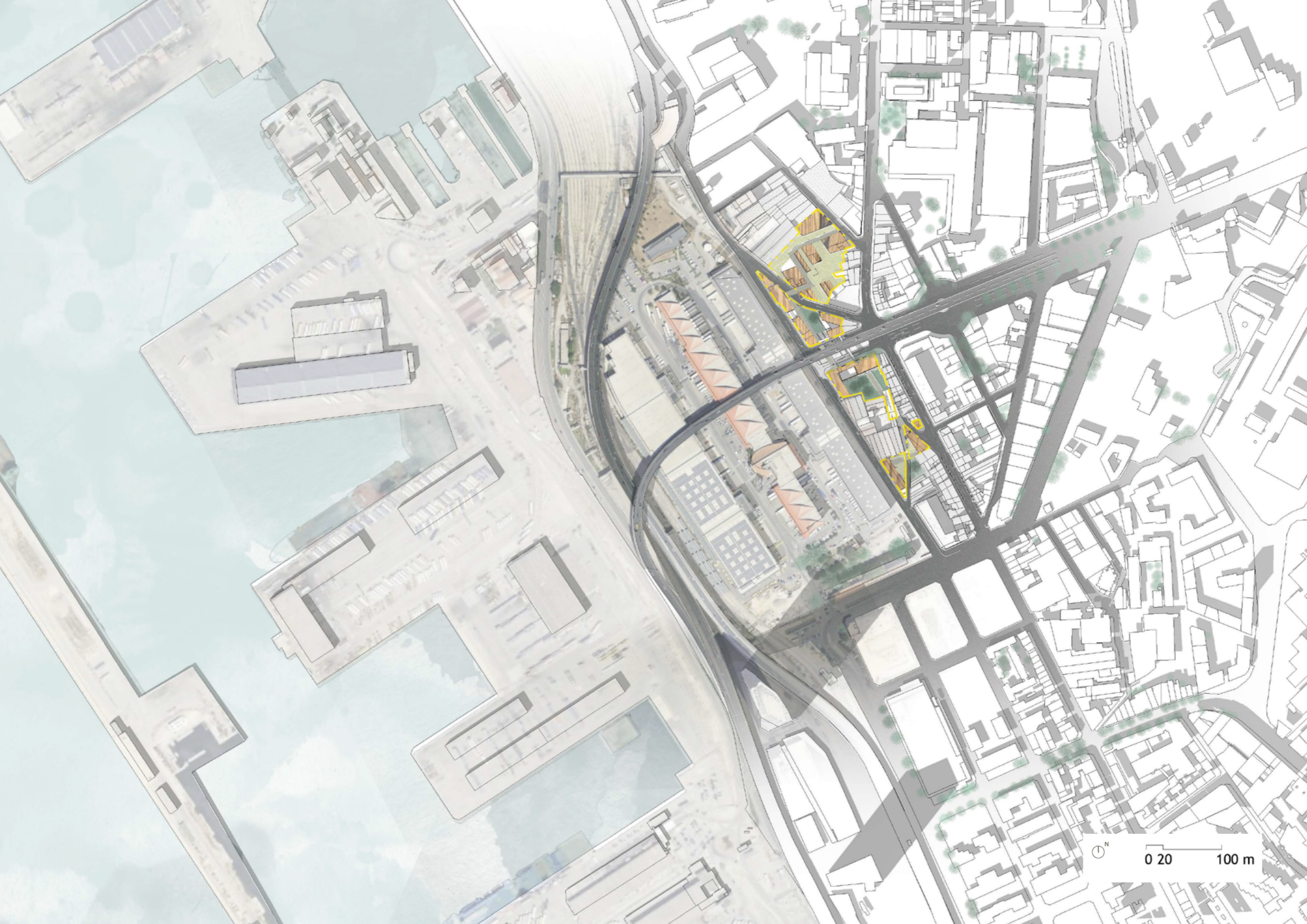

A site hemmed by infrastructure

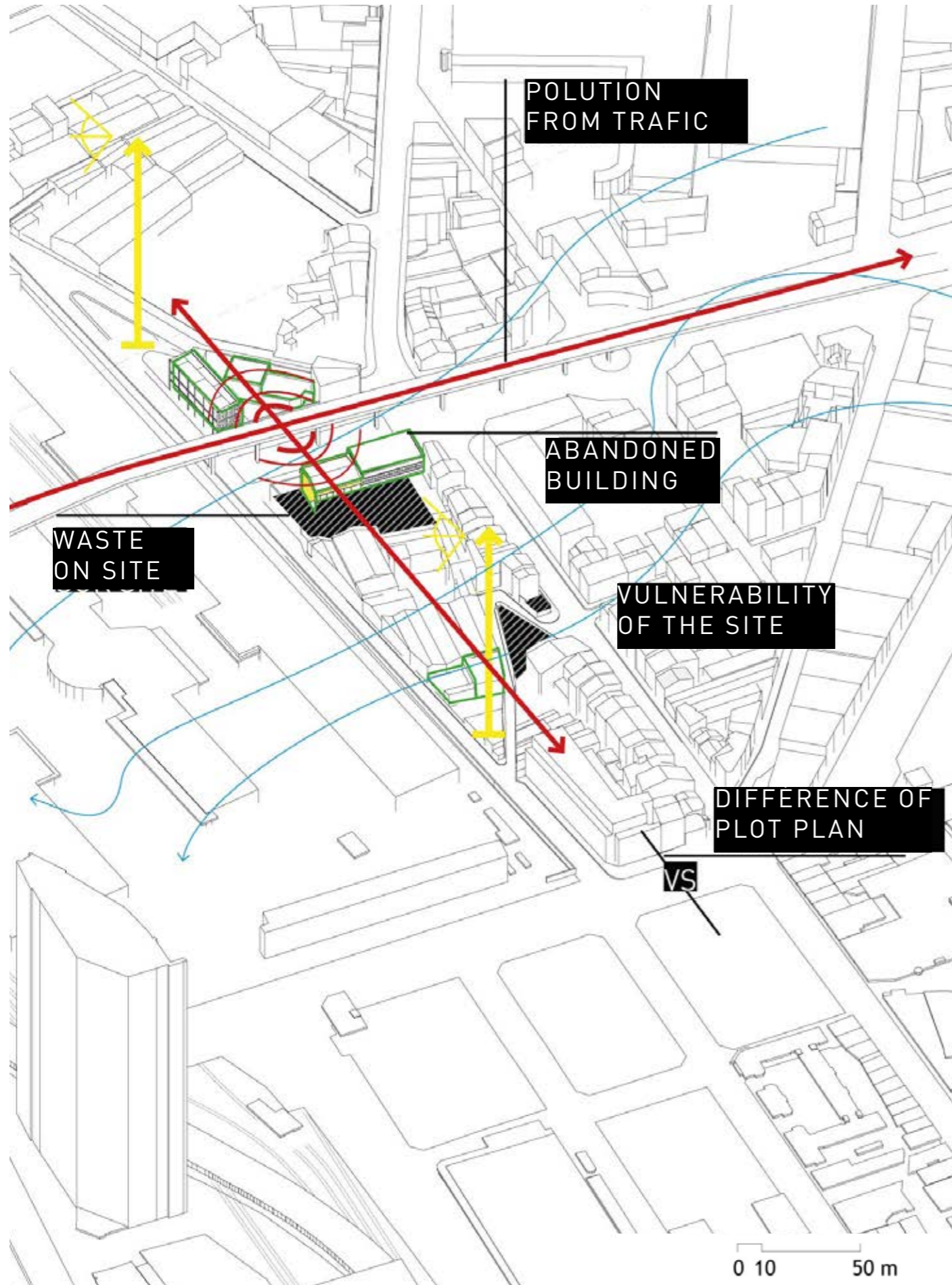

An industrial and local process

New building method

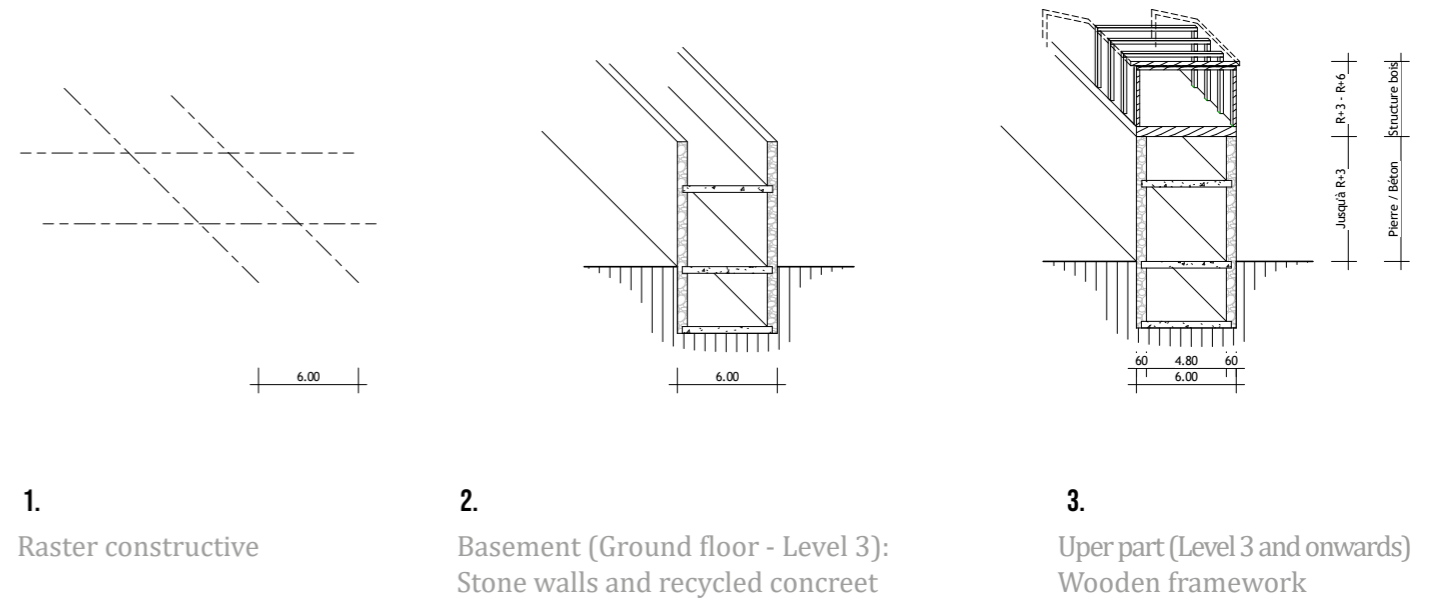

Rehabilitation method

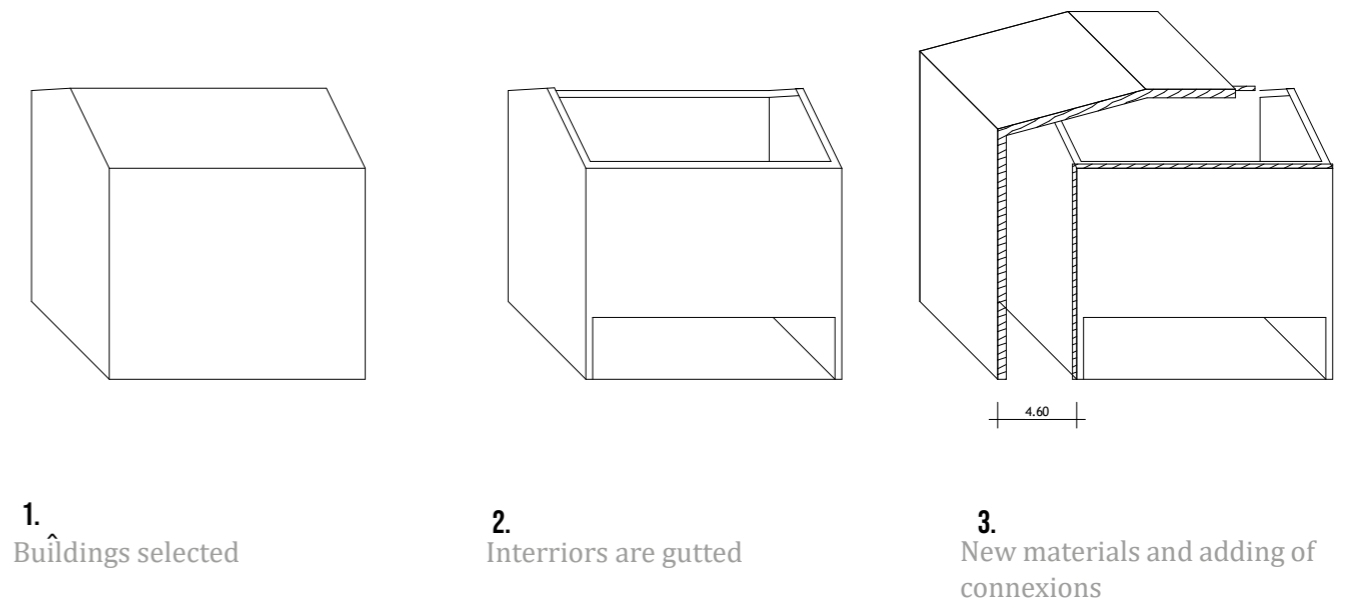





Section of Implantation on the site

Coursa Longitudinale - Lac vidée



Transformation method from the car to the façade

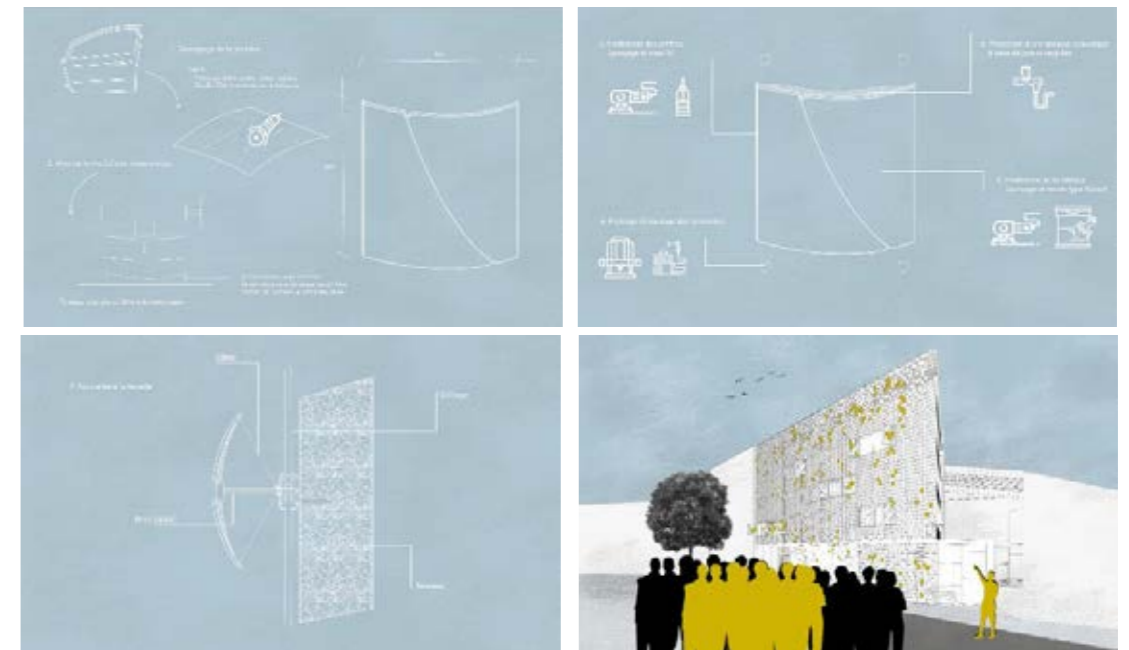

Production scenario

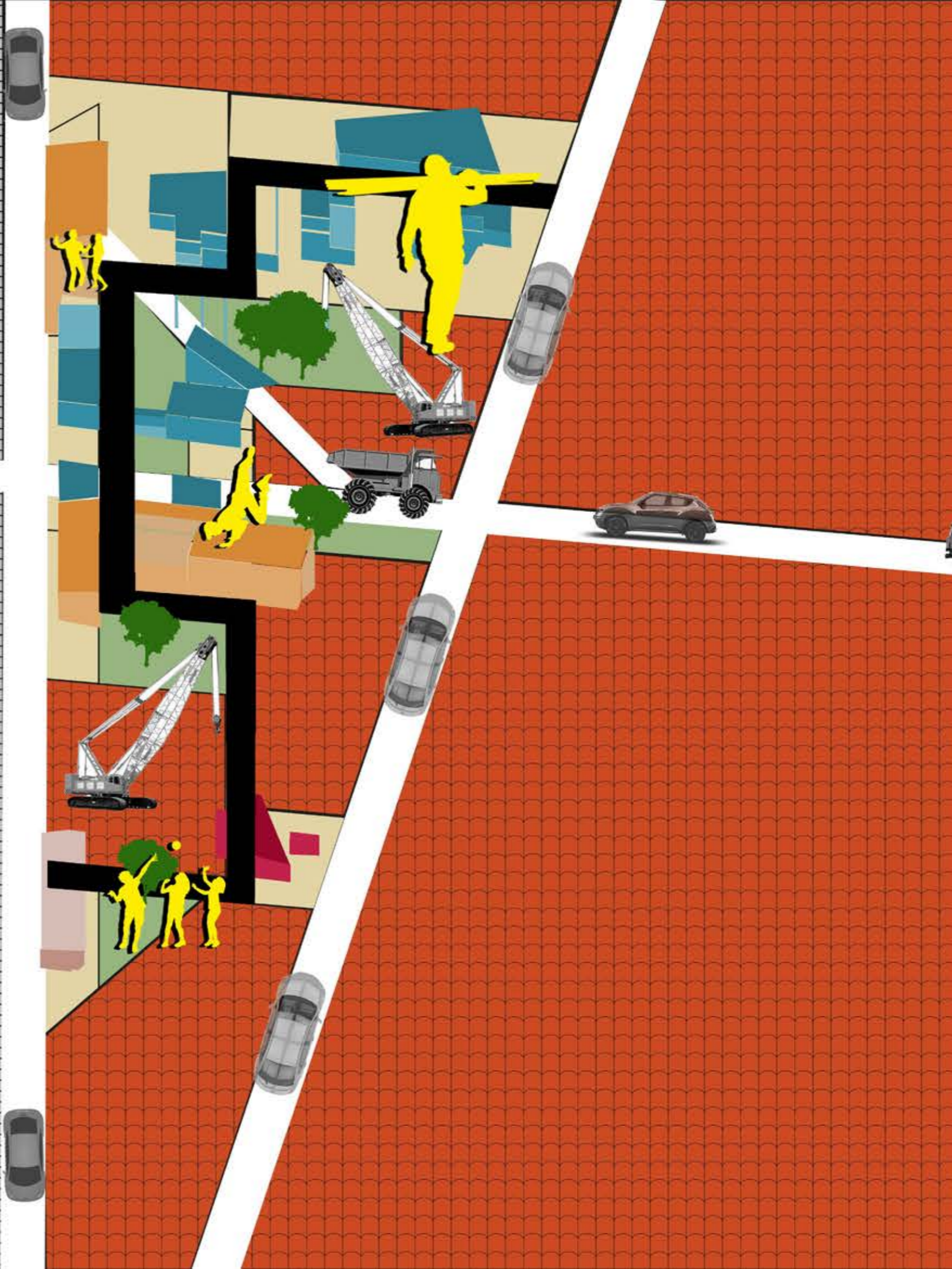
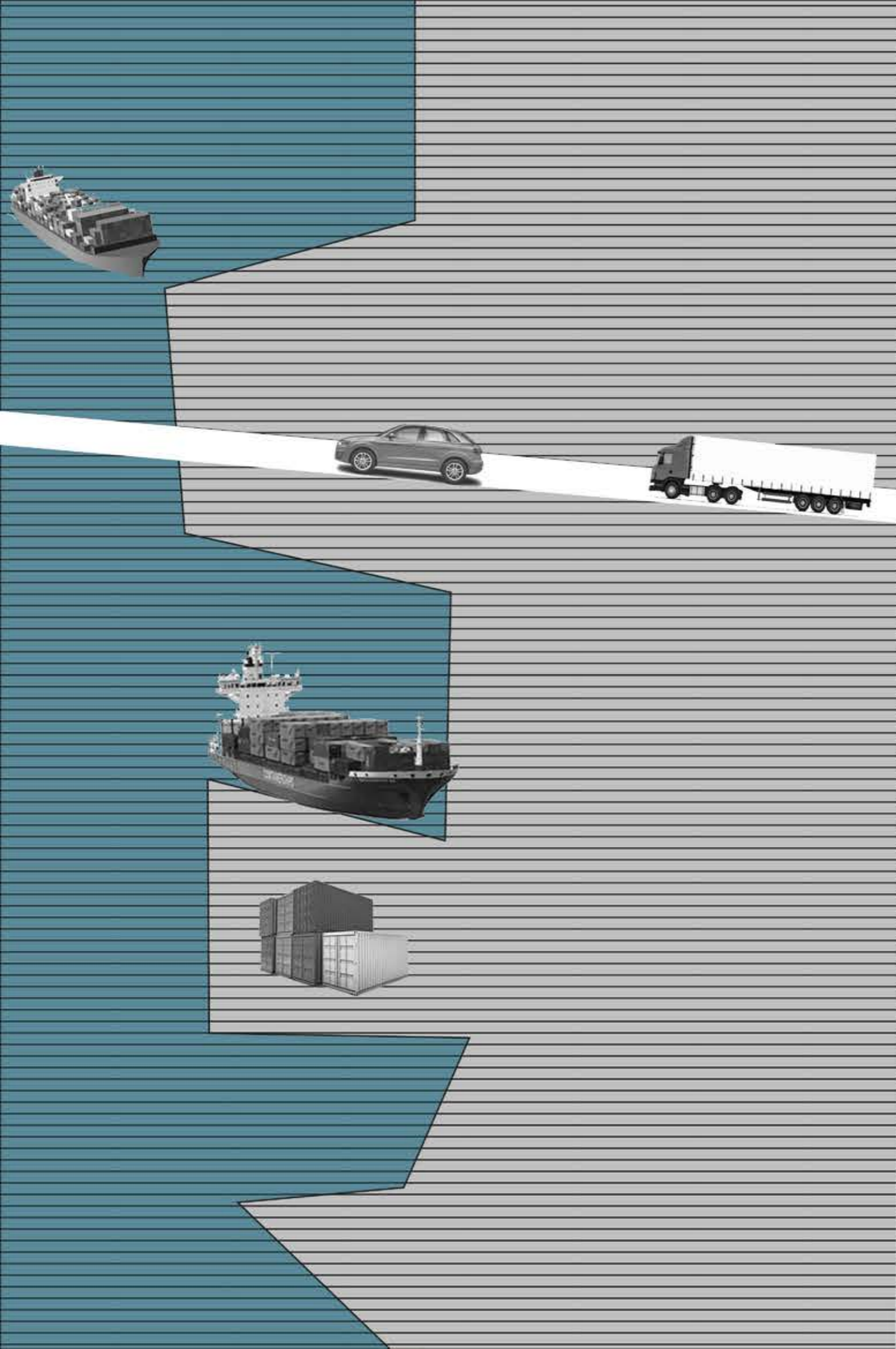

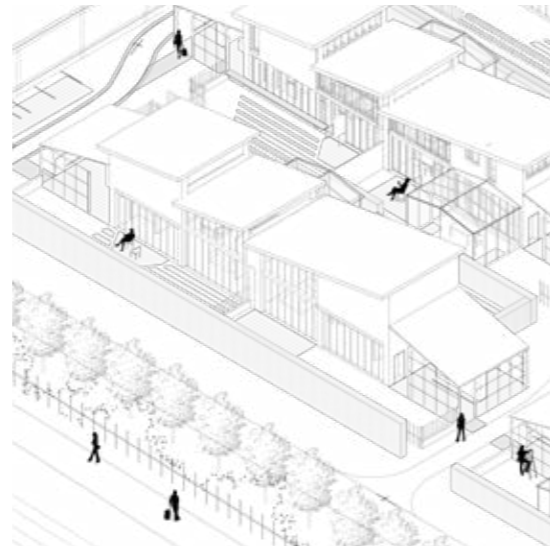

TRANS

2. RURAL LAB

THE FUTURE OF THE COUNTRYSIDE

Individual ENSA Paris-Val de Seine - YEAR 3 - 2017

How can rural areas conserve their exchanges with a low Carbon transport ?

Bicycles give people the opportunity to move in the scale of the city. Trains allow for movement between the city and the metropolitan area.

In this utopia :

- Inhabitants produce food on their own land.
- A food hall offers opportunity to exchange food: during temporary markets or all year long with a grocers.
- A recycling factory would store, reuse and transform people's objects.

Caulnes, a town in the French region of Bretagne, is suffering from a constant flow of trucks and cars. This situation gives us the opportunity to question the impact of cars on rural areas which are almost the only way to move. At the time of ecological transition, how can we keep those living areas without this tool of travel ? It's on the current space of multimodality space of the city that I decided to establish the project. I imagined a space without motor vehicles, the only way to move is the bike.

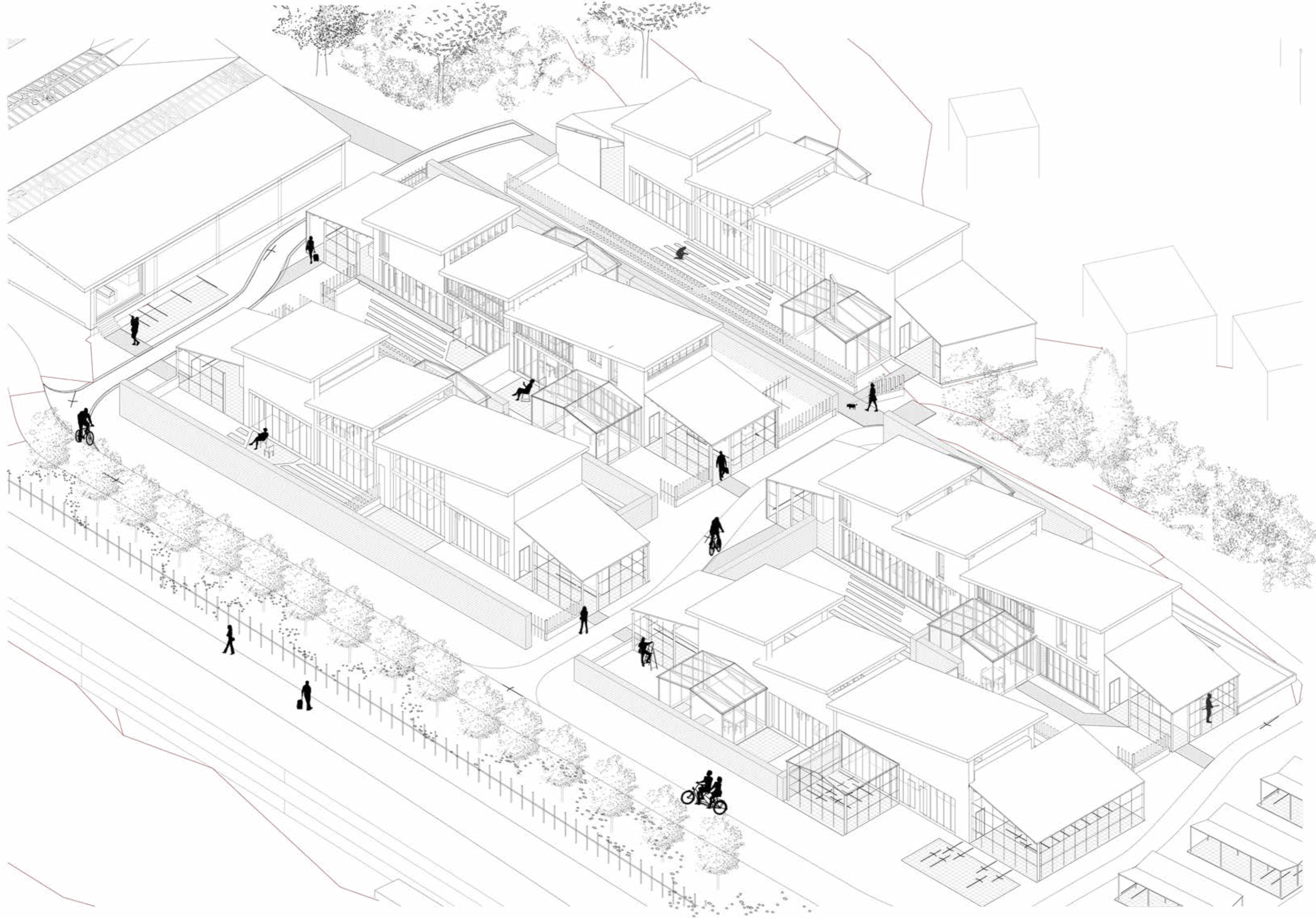



Today :

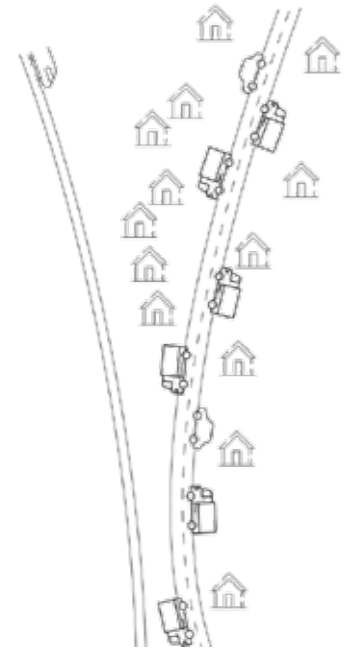

Tomorrow :

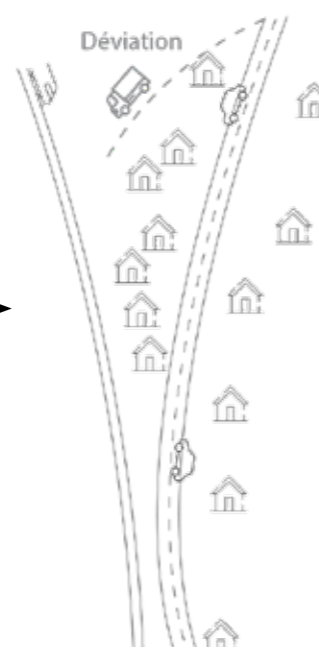

In 30 years :

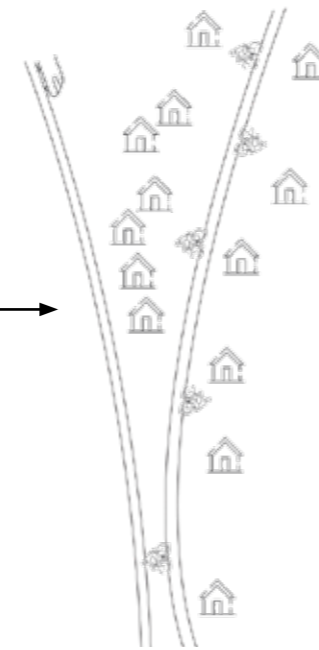

Scenario of evolution of society

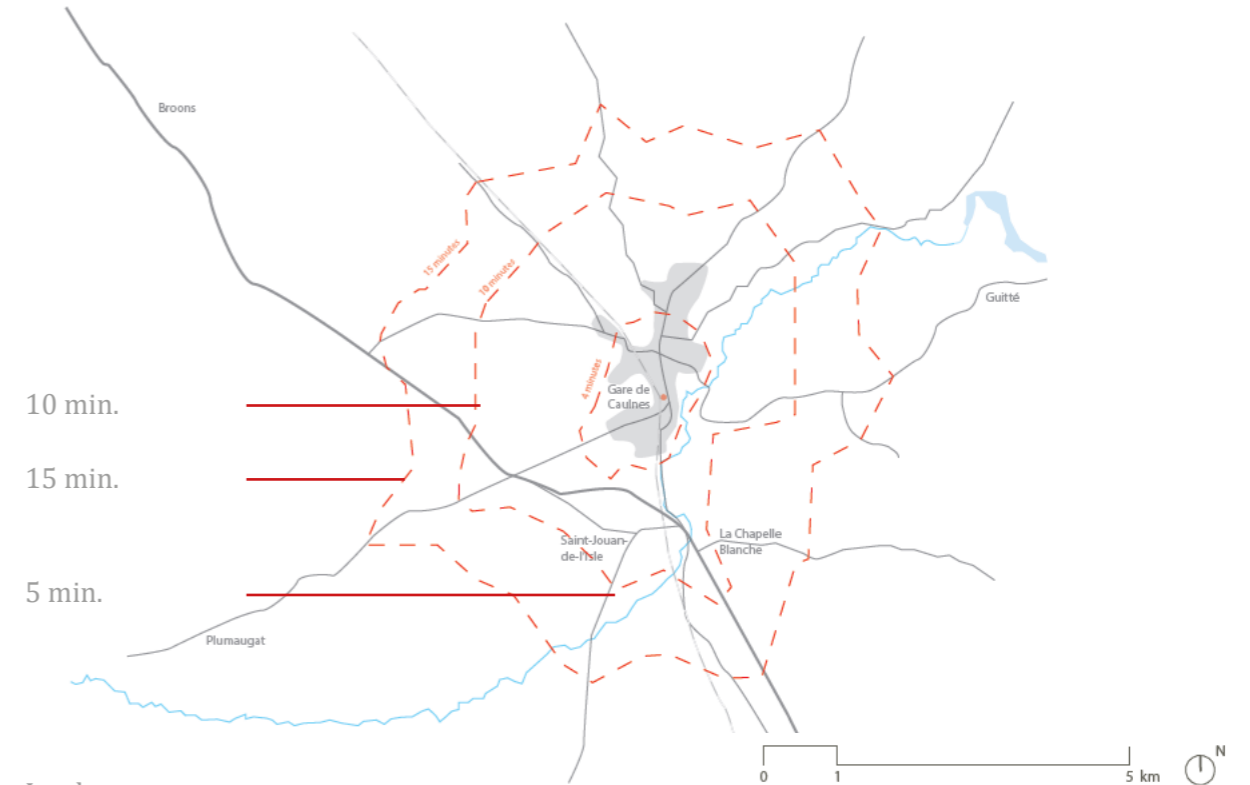

Isochron map

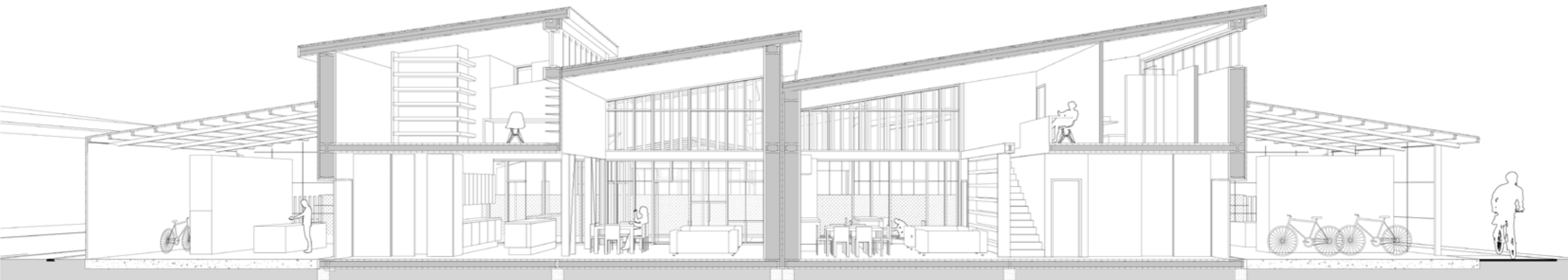

Perspective section of the terraced houses

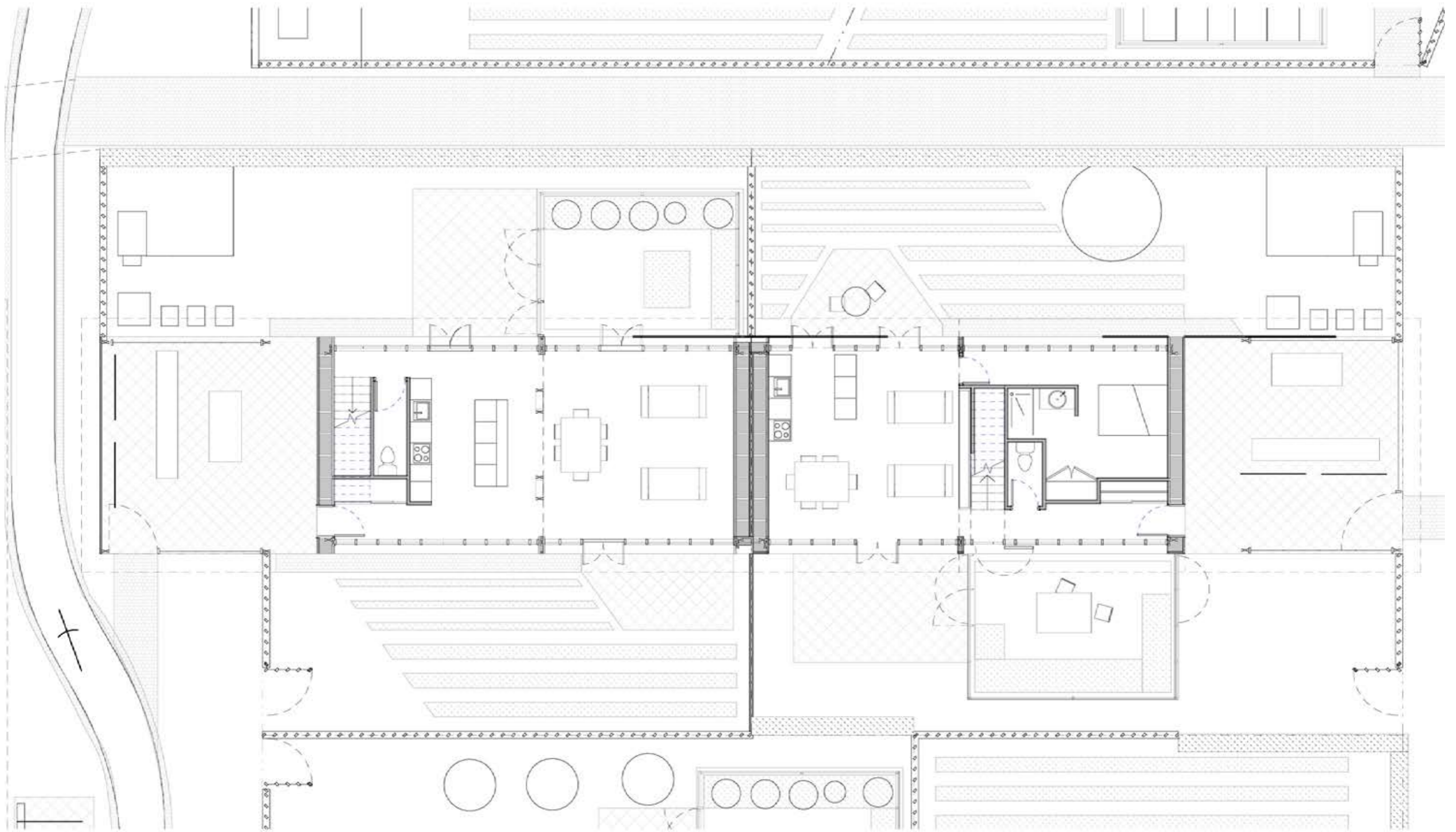

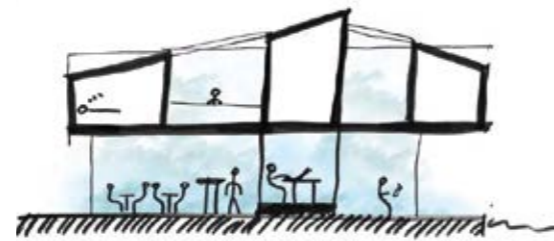

3. SYTOPIA

A MIXTE PROGRAMME

Individual Umea shcool of architecture - YEAR 3- 2018

A house for a family who needs to share, for them, and for their new child. The space is dealing with the notion of privacy and social cohesion. How a small space can offer both, from the tiny room to the public space of a cafe where a guest working and be a source of discussion. Moreover, the large scale of the project is a densified plan in cohesion with the ground pressure of the town.

In the north of Sweden, in the city of Umea. The point of departure of the project will be from the most common, yet underappreciated resources - water. After an investigation of the Umeaelven and his surrounding, the idea is to deal with the pressur of development of the city center and the necessity of housingspaces. According to the story of the inhabitants, the house will be shared with a public space.

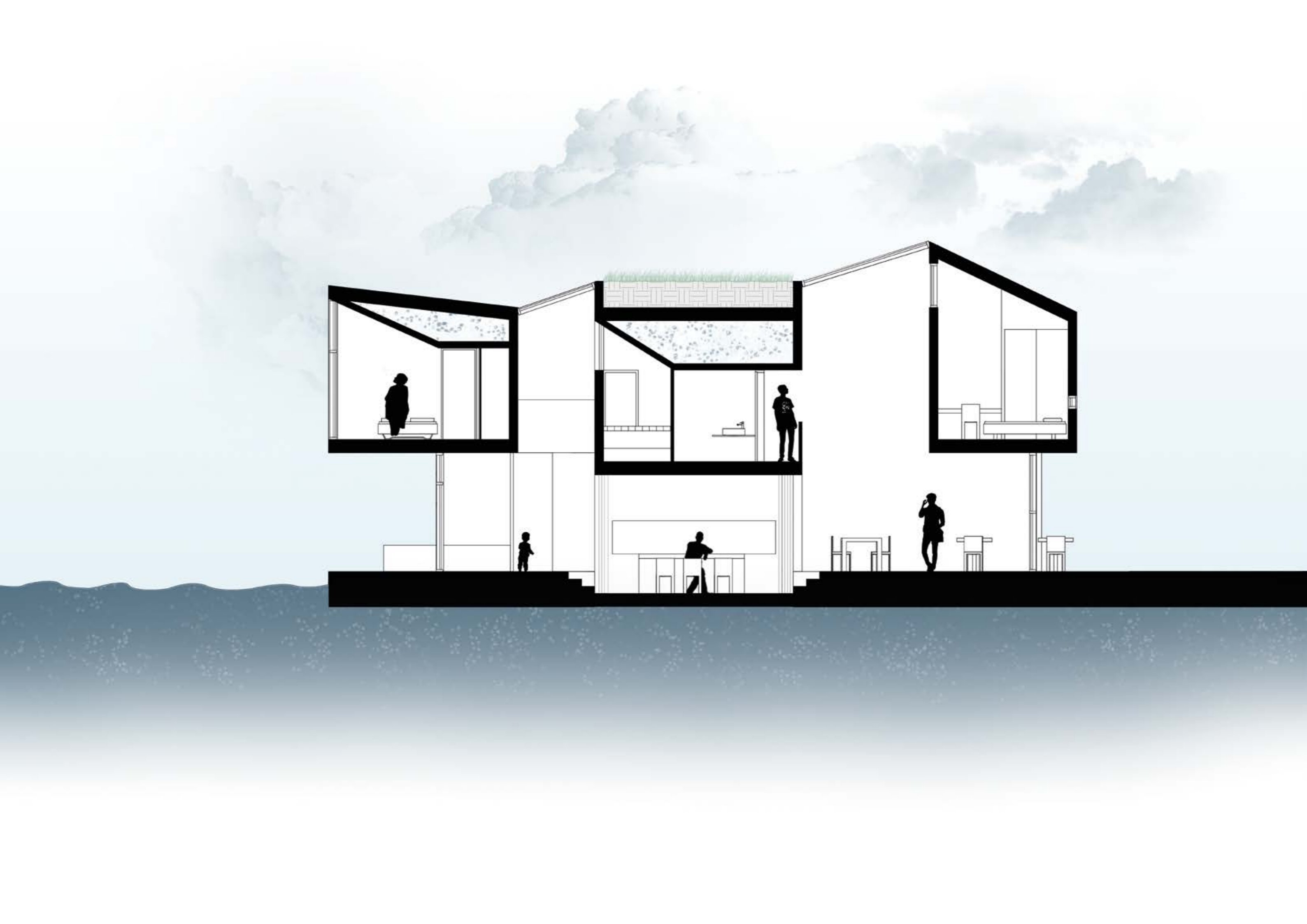

Defining the minimal space

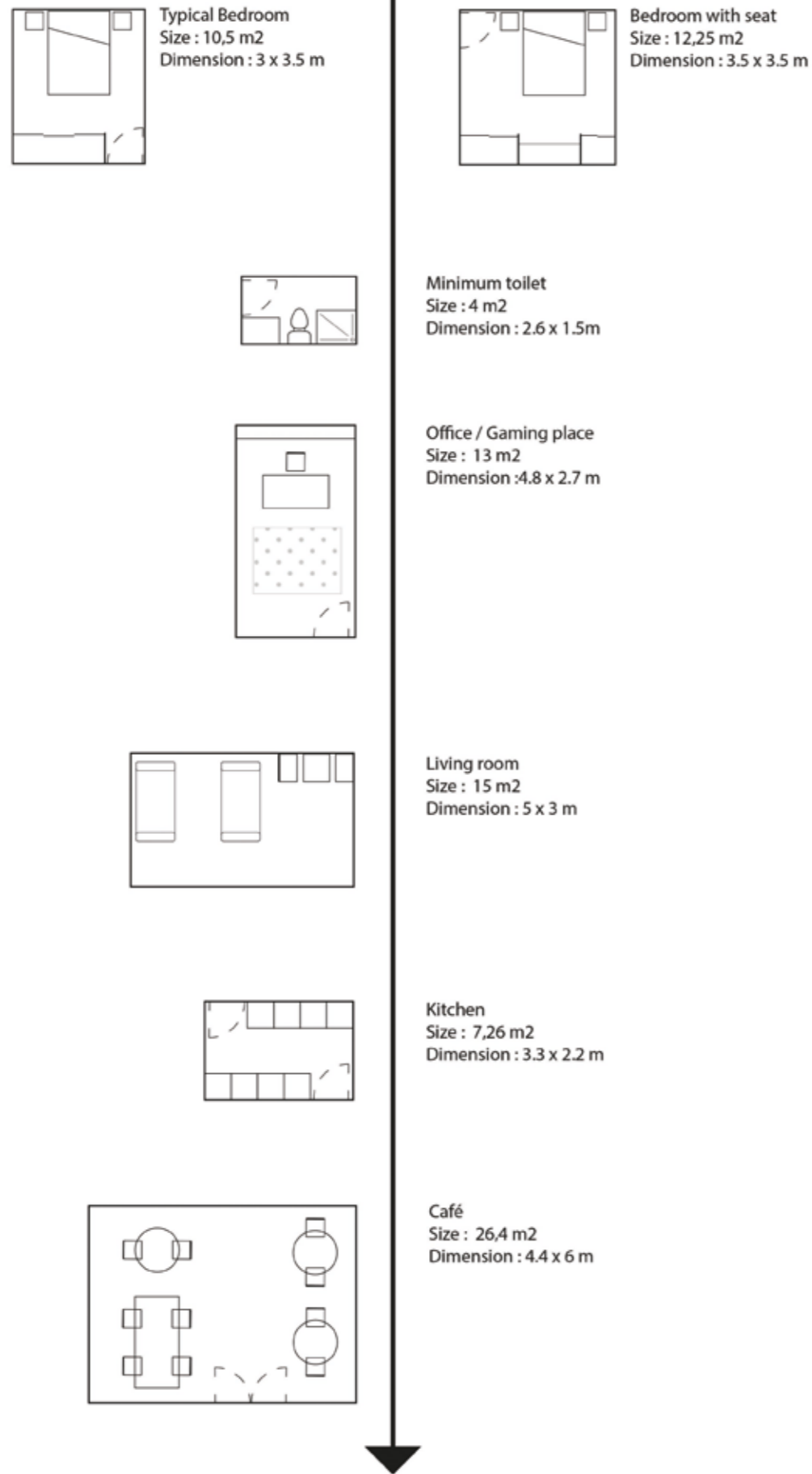

From the private to the public

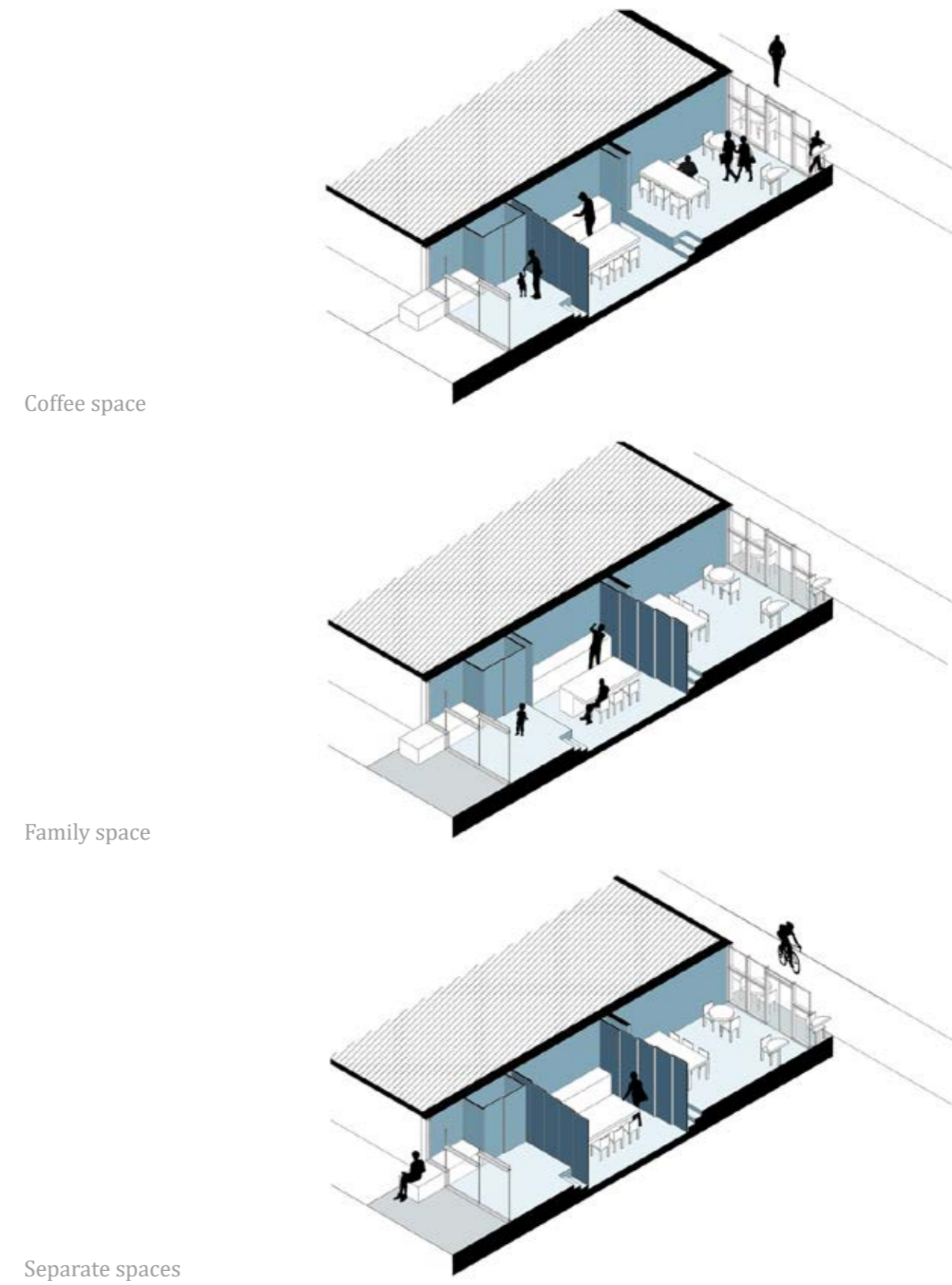

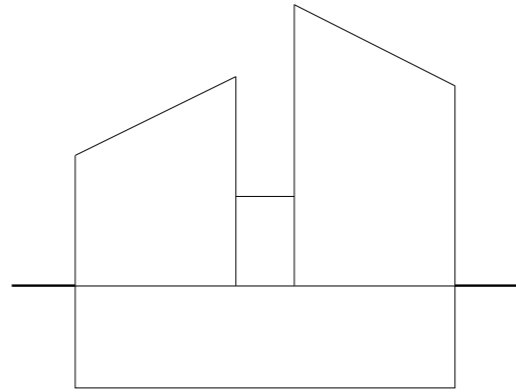

SLOAP

4. LIVING

A HOUSE IN SAINT-RAPHAËL

Individual ENSA Paris-Val de Seine - 2017

A « place to live » on a piece of land in Saint-Raphël in the south of France. It's composed of three bedrooms, and office, a living room and a kitchen for a surface of one hundred and forty square meters.

A faelt line fractures what we commonly call the archetype of a house. It's reveals the two visual aspects of the site: the sea and the generous vegetation. This faelt separates two zones and offers more tranquility and space to the living room. A base, which constitutes the lower level, gives a terrace which permit to benefit of the generous point of view of the sea. This house is in constant relation with the exterior, but without being an extension to it.



Studying the exposition of the sun

summer

winter

8 am

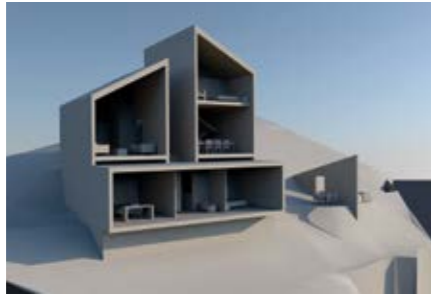

12 am



4 pm

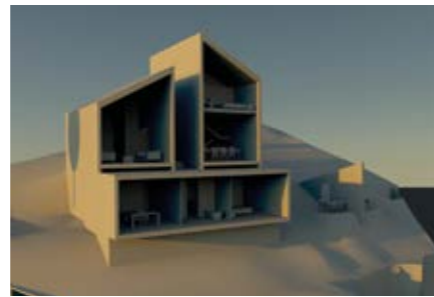

8 pm



the fealt revels on one side the sea and on the other side the vegetation

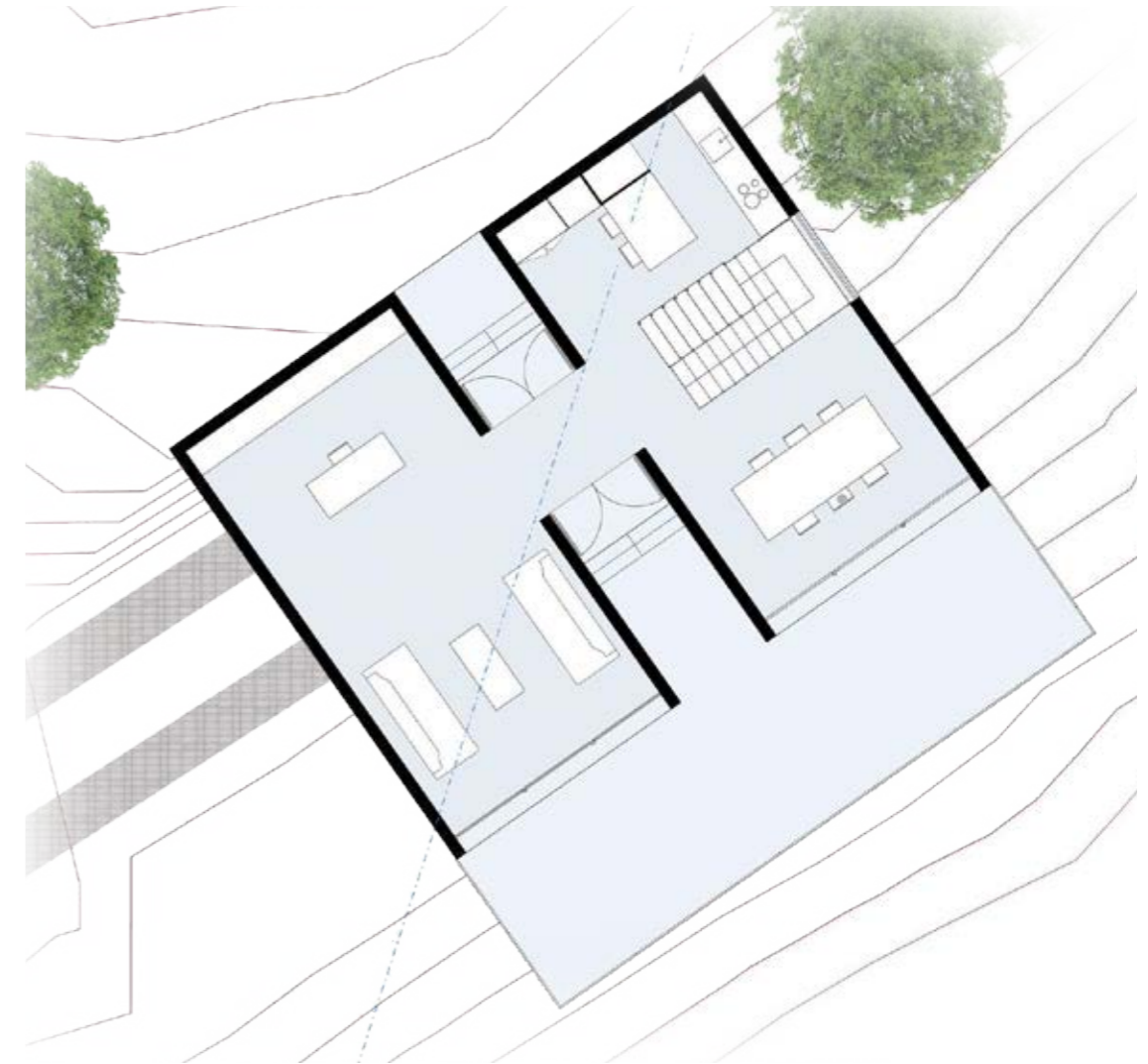

Ground floor



Plot plan



5. RESIDENCE

BEETWEEN PROFESSIONAL AND SOCIAL

Individual Private order - In progress - 2018

A building of double use: in one side an insurance office and on the other side a professional rental space which welcome a public to work and stay. By this expansion, the building will increase its capacity from 2 to 4 rentals. It needs to permit to high class reception for professional and at the same time provid a flexibility of use for having families, couples or just professionals.

Two extensions are physically connected to the actual building. One is placed behind the existing building in the north and is oriented to the garden. The second is a separation between the street and the garden and is oriented to the garden. Dwellings are sequenced to permit offices to welcome clients at the same time as having other guests who stay.



Adapting the exterios with the existing



Composition of the exterios finishings



Wooden shingle



Vertical clapboard



Horizontal Clapboard
(existing)



Roof

Openings adapted to the houses' proximity

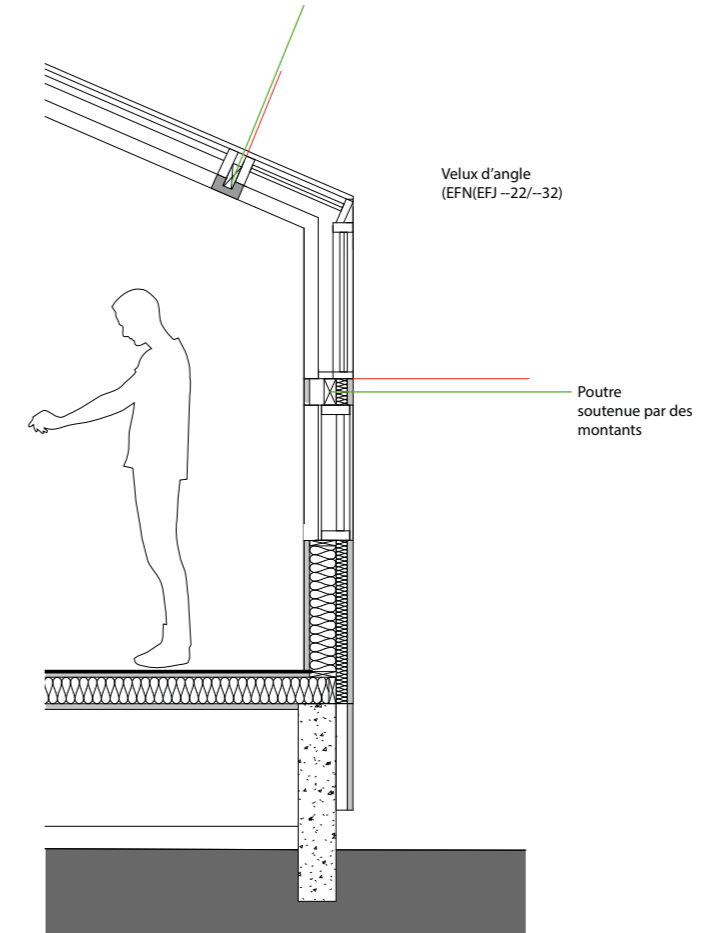

Excecution section



Lightning and disccussion

INTERESTS

Photography
Travel

Instagram

Architecture
in everyday life

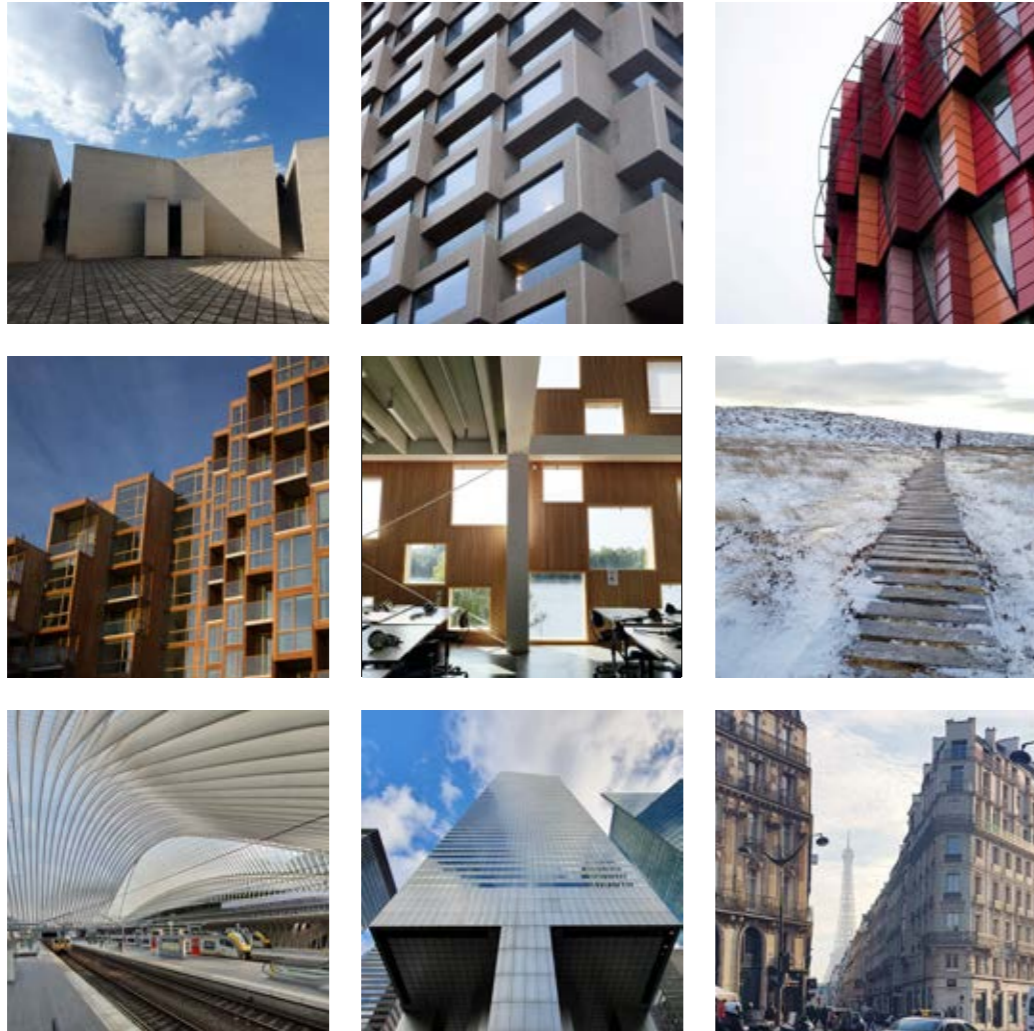

Photographic project

Curves

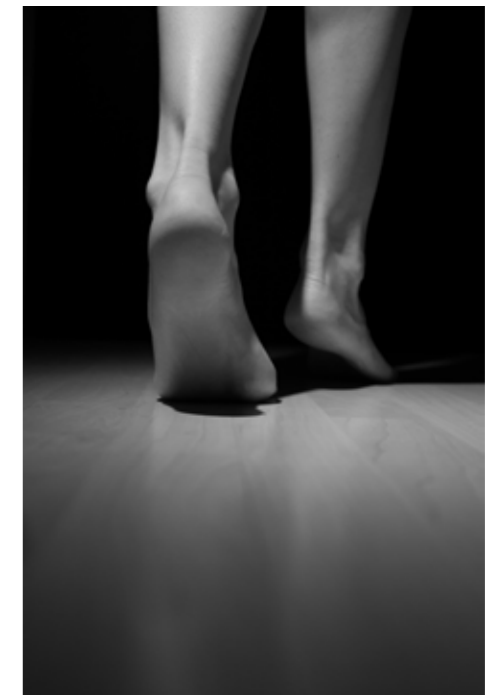
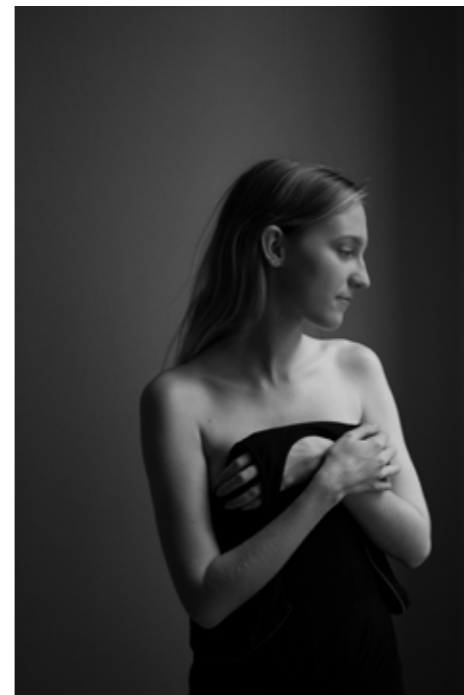
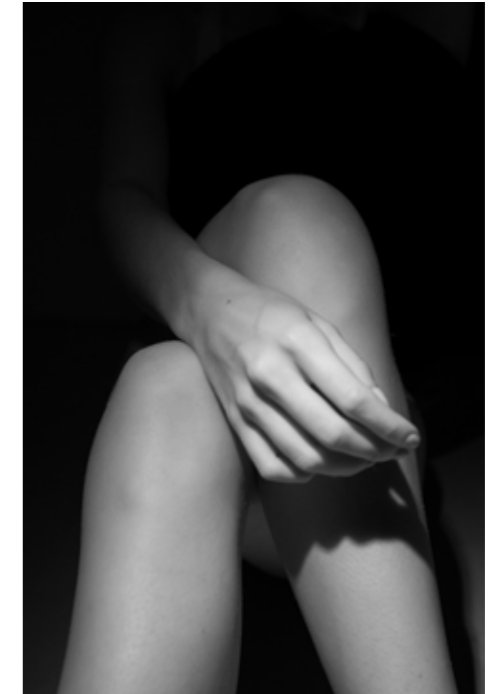

Photography

The limit,
Saint-Pierre-and-Miquelon



RECOMMENDATIONS

Pierre-Antoine GATIER

Architecte en Chef des Monuments Historiques
Inspecteur Général des Monuments Historiques

Pierre-Antoine Gatier
Architecte en Chef des Monuments Historiques
30, rue Guynemer 75006 Paris

Paris, le 17 octobre 2019

Objet : Lettre de recommandation

Madame, Monsieur,

Je soussigné Pierre-Antoine Gatier, Architecte en Chef des Monuments Historiques, certifie que Monsieur Quentin Lucas a bien réalisé un stage au sein de l'agence Pierre-Antoine Gatier du 04/02/2019 au 2/03/2019.

Dans le cadre de ce stage, Quentin Lucas a été amené à réaliser les missions suivantes:

- réalisation de pièces graphiques sur différents projets de l'agence (Parc de la Folie Sainte James à Neuilly-sur-Seine, Eglise Saint-Louis à Vincennes)
- recherches historiques (étude comparative de photographies d'archives)
- réalisation de dossiers photographiques (Château de Chantilly, Palais des Papes à Avignon, Parc de la Folie Sainte James)
- participation à des visites de concours

Quentin Lucas a su s'adapter rapidement à l'environnement de mon agence. Curieux et très impliqué, il s'est investi avec un grand professionnalisme dans l'ensemble des missions qui lui ont été confié.

Pour toutes ces raisons, je me permets de vous conseiller d'étudier attentivement sa candidature. Je reste à votre disposition pour tous renseignements supplémentaires que vous jugeriez utiles.

Veillez agréer, Madame, Monsieur, l'expression de nos respectueuses salutations.

Pierre-Antoine Gatier
Architecte en chef des monuments historiques
30 rue Guynemer - 75006 Paris
T. 01 40 46 88 66 / pierre-antoine@gatier.org

Pierre-Antoine GATIER

30, rue Guynemer 75006 Paris – Tél. 01 40 46 88 66
pierre-antoine@gatier.org



**Pierre-Antoine
GATIER**

Architect in chief of the
historical monuments

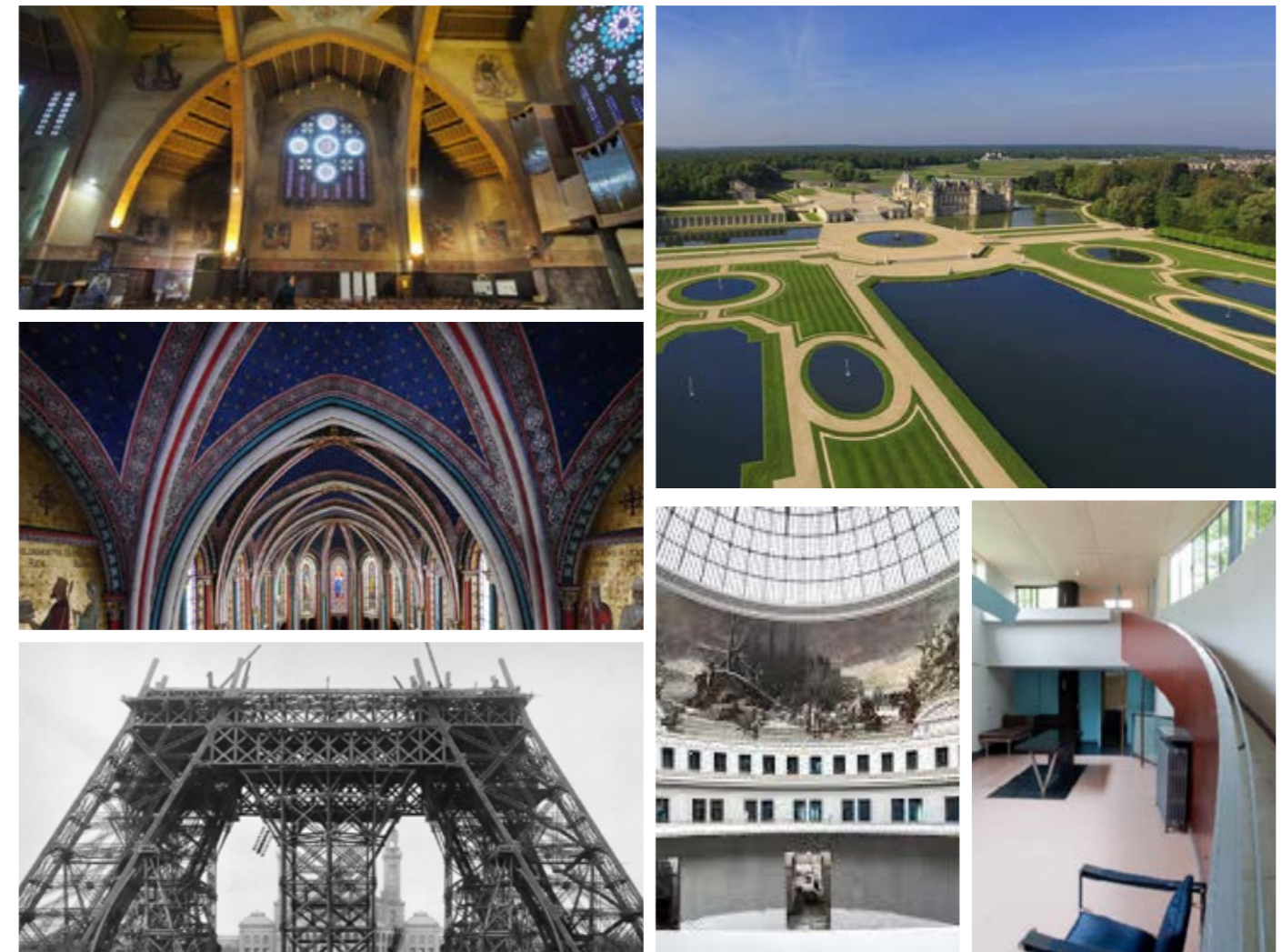



**Annick
GIRARDIN**

Minister of overseas islands



MINISTÈRE DES OUTRE-MER

La Ministre

Paris, le 21 octobre 2019

Madame, Monsieur,

Originaire de Miquelon, Monsieur Quentin LUCAS a pu effectuer, comme régulièrement les étudiants ultramarins présents dans l'hexagone, un stage d'une durée de trois mois au ministère des Outre-mer. Affecté à une mission logement auprès de Monsieur Olympio KYPRIANOU- PERRIMOND, conseiller en charge de cette thématique, il a pu expérimenter le travail en cabinet ministériel.

Depuis le 1^{er} septembre 2019, Monsieur Quentin LUCAS a pu participer au suivi des conclusions de la conférence logement en vue de l'élaboration du deuxième plan logement outre-mer, très largement attendu dans les territoires ultramarins afin de résorber l'habitat insalubre. Il a donc pu traiter la problématique de l'habitat pour tous, en travaillant sur les dispositifs d'aide à l'accession sociale. Il a aussi pu travailler sur la « trajectoire Outre-mer 5.0 » du gouvernement, répondant aux 17 objectifs de développement durable de l'agenda 2030 des Nations-Unies. Il a enfin participé aux délégations du ministère lors d'importants événements pour les acteurs du logement comme le Salon de l'Union Sociale pour l'Habitat ou encore le Congrès des Établissements Public Locaux.

Il a contribué en auteur principal à plusieurs notes internes sur des sujets architecturaux comme la conception modulaire ou encore sur l'évolution de la case Tomi, conception insulaire de La Réunion ou encore sur les recherches de matériaux bio-sourcés. Il a été en capacité de contacter des partenaires et de motiver un soutien de projets en cohérence avec des politiques durables et sociales.

Pour toutes ces raisons et connaissant son intérêt pour une architecture durable et sociale, je recommande fortement Monsieur Quentin LUCAS pour un stage au sein de votre agence.

Mon équipe, à commencer par son maître de stage, se tient à votre disposition pour toute information complémentaire.

Je vous prie d'agréer, Madame, Monsieur, l'expression de ma considération distinguée.

Annick GIRARDIN

27, rue Oudinot - 75358 PARIS 07 SP - Tél. 01 53 69 20 00

Internet : www.outre-mer.gouv.fr

GUADELOUPE GUYANE MARTINIQUE MAYOTTE NOUVELLE-CALÉDONIE POLYNÉSIE FRANÇAISE LA RÉUNION SAINT-BARTHÉLEMY SAINT-MARTIN SAINT-PIERRE-ET-MIQUELON TERRES AUSTRALES ET ANTARCTIQUES FRANÇAISES WALLIS-ET-FUTUNA

LETTRE DE RECOMMANDATION

à Paris,
le 19 mars 2021

À qui de droit :

Notre agence Silvio d'Ascia Architecture a eu le plaisir de collaborer avec Quentin LUCAS pendant cinq mois, du 06 janvier 2020 au 29 mai 2020, en qualité de stagiaire.

À ce titre, Quentin a été amené à produire des dessins et visuels 2D et 3D pour les projets suivants :

- Commerce phygital, bureaux et restaurants à Miserey-Salines
Production graphique
- Ecoquartier des Aéraulians à Tremblay
Modèle REVIT, Twinmotion, dossier de présentation sur Indesign
- Extension de La Fondation Maeght à Saint-Paul de Vence
Esquisse préliminaire, dessins (coupes...), élaboration du dossier sur Indesign

Ces travaux lui ont permis d'approfondir des qualités nécessaires au métier de dessinateur telles que la compréhension des enjeux d'un projet, la qualité des livrables, la capacité à prendre en compte les remarques émises par les chefs de projet ou encore la gestion du temps, d'un planning.

Quentin a su s'intégrer aisément au travail quotidien de l'équipe ainsi qu'à la vie de l'agence. Et cela, en dépit du contexte sanitaire, durant lequel nous avons dû appréhender ensemble une nouvelle manière de travailler, de communiquer et d'échanger à distance.

Nous remercions Quentin pour son ouverture, son écoute, son sérieux, sa disponibilité et nous vous le recommandons sans hésitation. Nous restons à votre disposition pour de plus amples renseignements.

Nous vous prions d'agréer, Madame, Monsieur, l'expression de nos salutations distinguées.

vous pouvez nous appeler au **+33 (0) 177 19 74 17**
nous écrire à **contact@dascia.com**
nous trouver au **15 rue de Palestro, 75 002 Paris**
nous retrouver sur **www.dascia.com**



**Silvio
d'Ascia**

Architect
Grand prize of Versailles

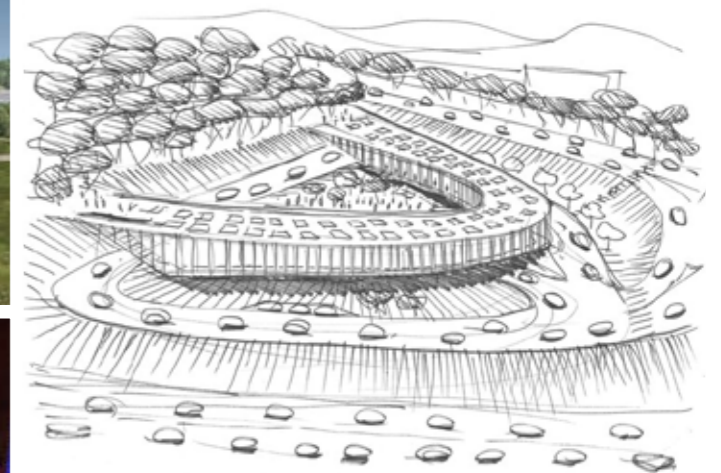

Thank you



Quentin LUCAS

www.quentinlucas.com
mars 2021